

Electronic Geophysical Year - eGY

International Association of Geomagnetism and
Aeronomy task force

D.N. Baker, C.E. Barton, B.J. Fraser, V. Papitashvili,
A.S. Rodger and B.J. Thompson



**British
Antarctic Survey**

NATURAL ENVIRONMENT RESEARCH COUNCIL



The IGY plus 50 years: New Perspectives for the Next Millennium

WE THEREFORE CALL UPON the IUGG and all interested Associations to join SCOSTEP in a RESOLUTION to declare the period 2003 to 2008 THE IGY plus 50 years: New Perspectives for the Next Millennium. In so declaring, SCOSTEP plans to invite all ICSU-related Unions to endeavor to build a program of worldwide research into the geophysics, geochemistry, biology, and dynamics of the solar-terrestrial and solar-planetary systems.



The IUGG response

Celebrations to commemorate the IGY

An electronic Geophysical Year (eGY)

eGY Objectives

- Digitise and make available analogue records
- Make existing data sets available
 - Free access to all
- Develop a system of Virtual Observatories

Embrace and extend the IGY principles of data sharing and scientist involvement

To get scientific data from various, mostly distributed sources, a scientist may have to:

1. Search through a number of data centres, various institutions, observatories, contact colleagues...



2. Get data via snail-mail, air-mail, e-mail, Web...

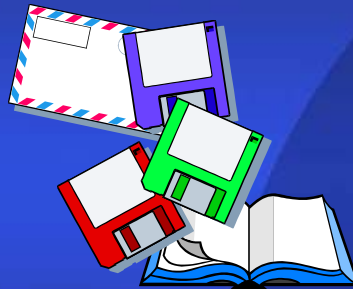

3. Then ingest retrieved data into a local database...

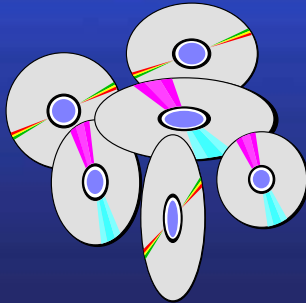

4. Process collected data using mostly proprietary codes, run models... and...



5. Finally, do some science

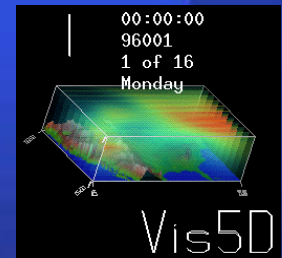

Increasing requirements

Earth system science

Higher resolution - space and time

Assimilation into models

Virtual observatory components

Distributed data bases accessed through a
single portal

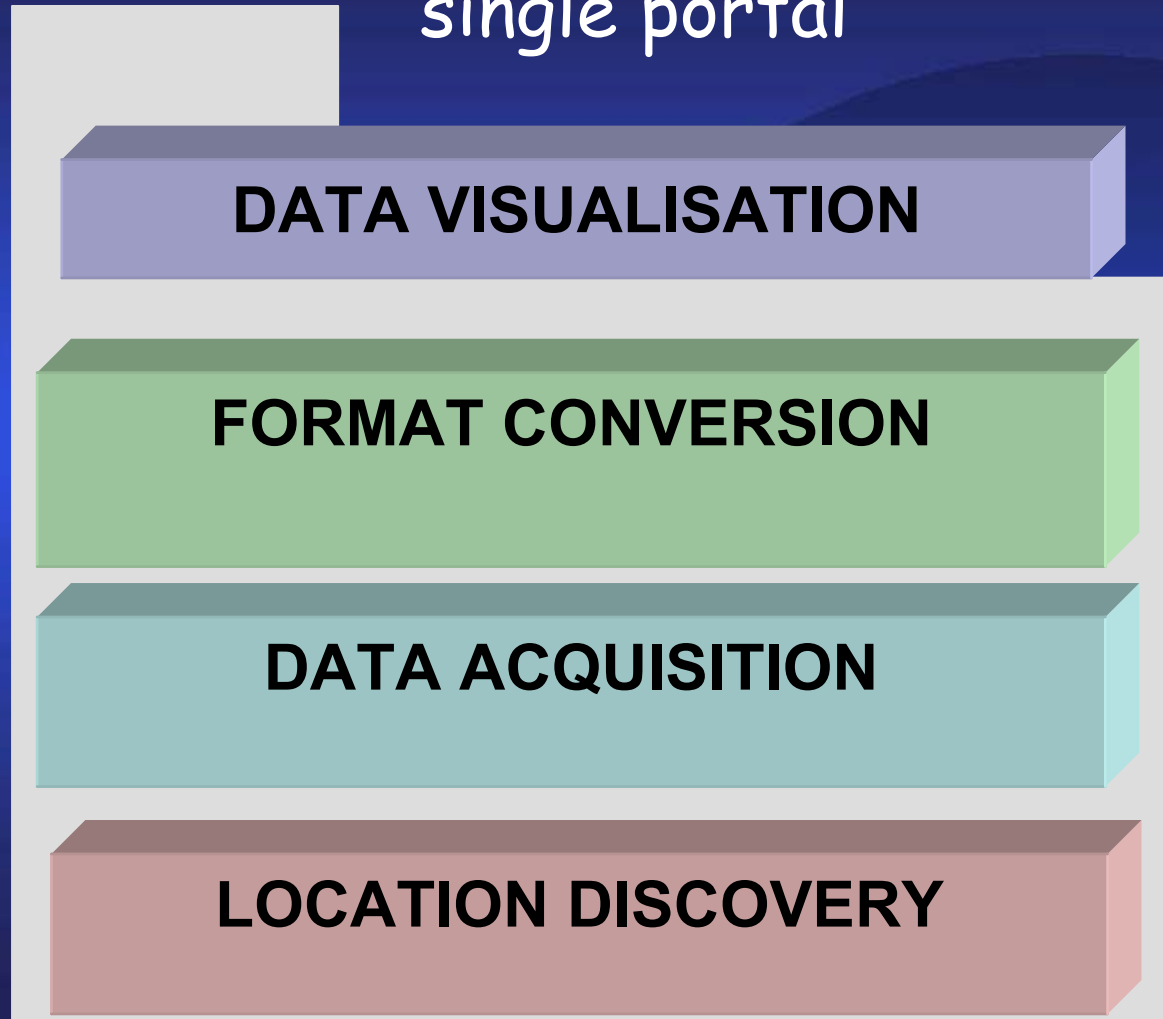

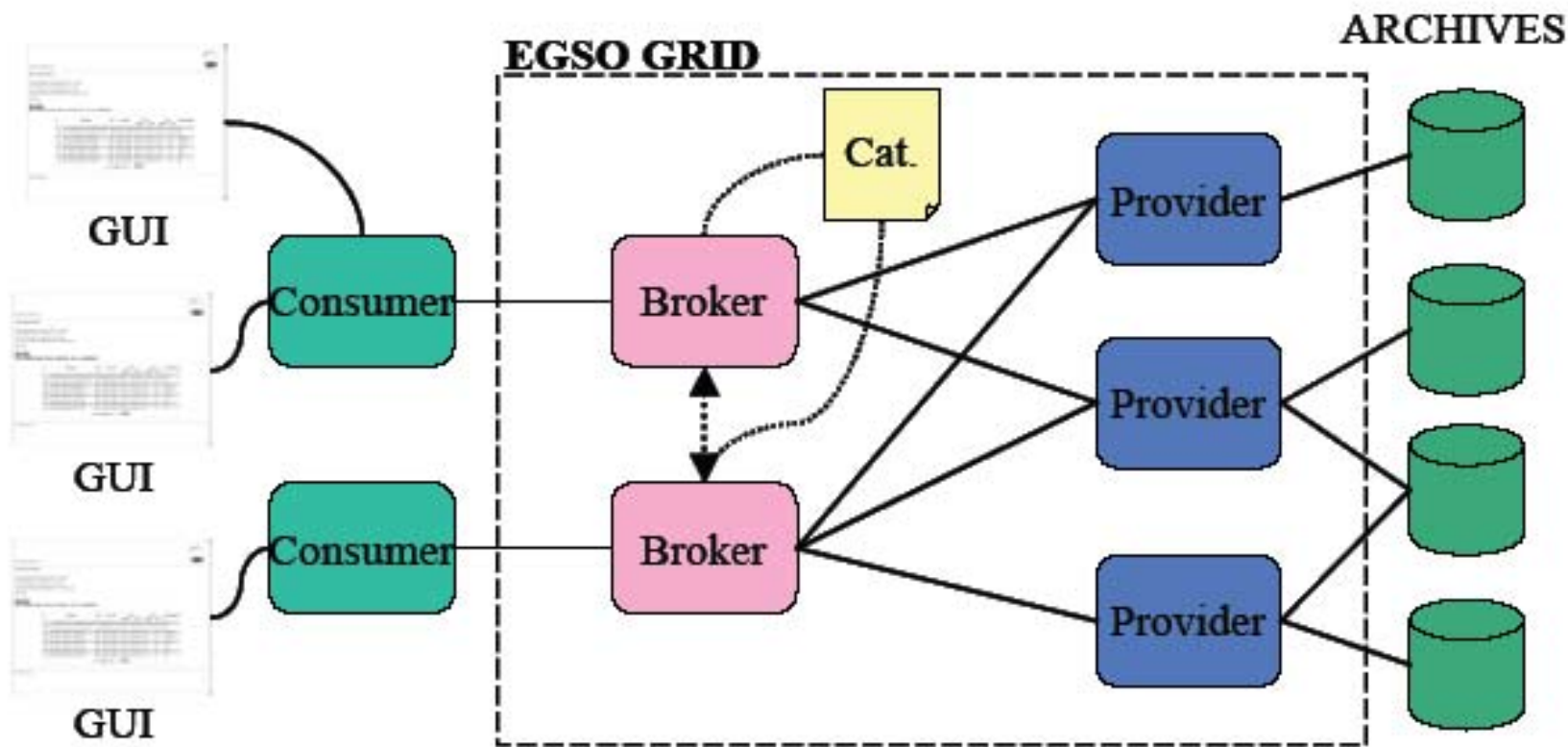

Architecture defined in terms of roles

Consumer, Broker and Provider

The Virtual Solar Observatory

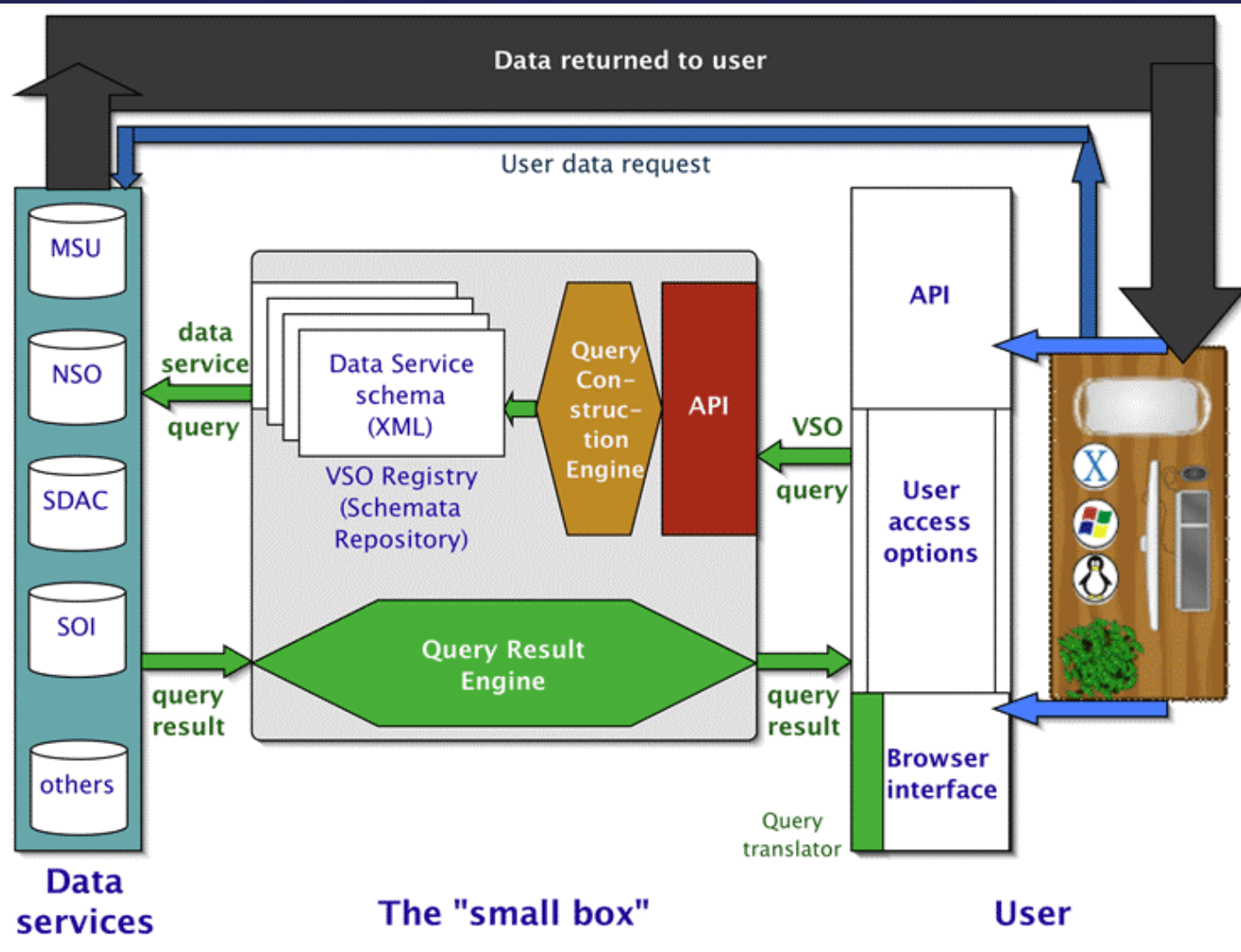

- Access through a browser or an Application Programming Interface (API)
- "Small box" uses registry of XML data service schema to construct appropriate queries for each relevant data service
- API or browser can refine queries
- Final data transfer is direct to requestor (no middleman)

eGY - initial timeline

2003

- July IUGG Gen. Assy, Sapporo endorsed eGY
- Dec eGY planning discussion at AGU

2004

- March Paper describing eGY in Eos
- March Submitted ICSU grant application
- July eGY workshop
- Sept IUGG Executive meeting

2005

IUGG Association meetings

Presentations and planning

eGY Characteristics

- Timeliness - Virtual Observatory software becoming available
- Interdisciplinary - data sharing and data accessibility common issues in all fields of geophysics
- Affordable - simple technology
- Cost effective - more/better science for money
- Inclusive - opportunities for developed and developing countries
- Capacity Building - provide relevant research experience for younger scientists
- Complementary to IPY and other I*Y initiatives

electronic Geophysical Year Summary

- eGY Objectives
 - Digitise analogue records
 - Make existing data freely available
 - Develop a system of Virtual Observatories
- Much planning to be done
- Complementary to IPY

